

Schnellwechsel-System mini-fix

Quick-change system mini-fix



Katalog Nr. 160
Catalogue No. 160

Schnellwechselbar und voreinstellbar
Quick-change and pre-setting function





Schnellwechsel-System mini-fix

für Mehrspindel-Drehautomaten, Sondermaschinen etc.

Schnellwechselbar und voreinstellbar

Einführungsspiel der Wechseleinsätze 0,2 mm

Rundlaufgenauigkeit < 0,01 mm

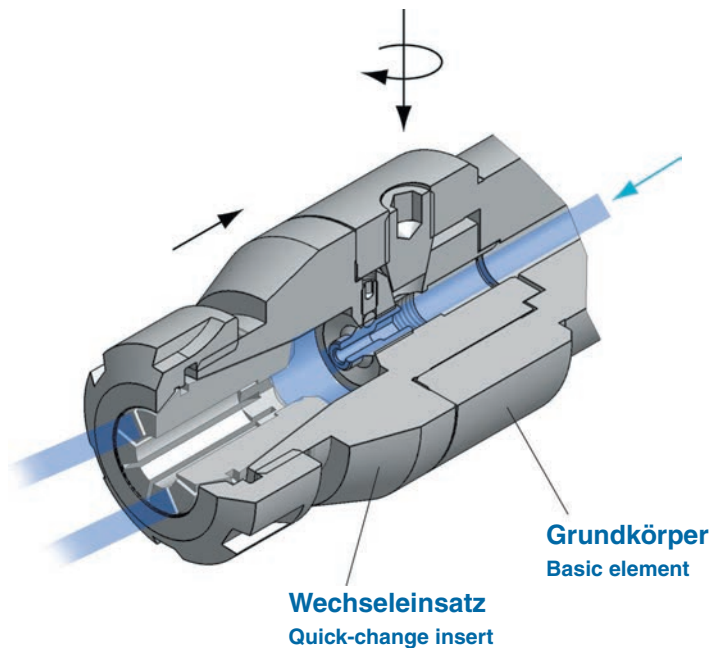

Quick-change system mini-fix

for multiple automatic lathes, special machines etc.

Quick change and pre-setting function

Leading-in motion of the interchangeable inserts 0.2 mm

Concentricity < 0.01 mm

Werkstoff: Legierter Einsatzstahl mit einer Zugfestigkeit im Kern von min. 800 N/mm

Ausführung: Einsatzgehärtet HRc 60 -2 (HV 700 ± 50)
Härtetiefe 0,8 mm -0,2
Brüniert und präzisionsgeschliffen

Material: Case hardened steel, tensile strength in the core min. 800 N/mm

Execution: Case hardened HRc 60 -2 (HV 700 ± 50)
Depth of case 0.8 mm -0.2
Brown-finished end precision ground

Technische Änderungen vorbehalten · We reserve the right to make technical changes.

Allgemeine Verkaufsbedingungen finden Sie auf unserer Website:

Visit our website for General Condition of Sales:

www.zuern-tools.de/agb

Produktgruppen Product groups	Seite Page
Grundkörper mit zylindrischem Schaft / Grundkörper SAY 20-6 Basic element with cylindrical shank / Basic element SAY 20-6	4
Grundkörper / Schnellbohrspindel für SAY 25-6 + SAY 32-6 Basic element / High-speed drilling spindle for SAY 25-6 + SAY 32-6	5
Grundkörper / Schnellbohrspindel für INDEX MS25 Basic element / High-speed drilling spindle for INDEX MS25	6
Grundkörper für Schütte mini-fix Größe 6+7 Basic element for Schütte mini-fix size 6+7	7
Wechseleinsatz Spannzangenfutter Quick-change insert collet chuck	8
Wechseleinsatz Pendelhalter / Gewindeschneidfutter Quick-change insert floating holder / auto tapper	9
Wechseleinsatz Zylinderschaftaufnahme DIN 1835 B/E Quick-change insert holder for straight shank tools DIN 1835 B/E	10
Wechseleinsatz Ausdrehkopf System Zürn / Spannzangenfutter Universal Quick-change insert boring head System Zürn / collet holder	11
Wechseleinsatz Räumhalter für Innenprofile / Stempel Quick-change insert broaching toolholder for internal profiles / Broaching cutters	12-13
Wechseleinsatz Spannzangenfutter radial feinverstellbar / Rohling Quick-change insert collet chuck radially fine-adjustable / blank	14
Spannmuttern / Dichtscheiben Clamping nuts / Sealing discs	15-17
Spannzangen Collets	18-19

Grundkörper mit zylindrischem Schaft
Basic element with cylindrical shank

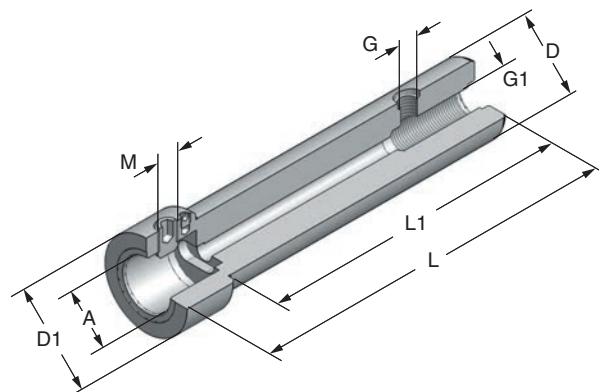

Art.-Nr.	Typ	A	D h6	D1	G	G1	L	L1	M	Nm	M-Art.-Nr.
135105		18	22	32		ø5	78	48	M8x1	25	101100
146105	G 39.01	22	25,4	39	G1/4"		78	48	M10x1	35	111100
237105		22	30	39	G1/4"	G3/8"	200	170	M10x1	35	111100
149105	G 39.04	22	40	40	G1/4"	G3/8"	200		M10x1	35	111100
150105	G 39.05	22	40	50		M12	97	75	M10x1	35	111100
161105	G 50.01	28	25,4	50			84	48	M12x1	45	121100
162105	G 50.02	28	38,1	50	G1/4"	G3/8"	190	160	M12x1	45	121100
163105	G 50.03	28	40	50	G1/4"	G3/8"	200	170	M12x1	45	121100
164105	G 50.04	28	50	50	G1/4"	G3/8"	200		M12x1	45	121100
165105	G 50.05	28	50,8	50,8	G1/4"	G3/8"	200		M12x1	45	121100
166105	G 50.06	28	40	50		M12	105	75	M12x1	45	121100
167105		28	63,5	63,5	G1/4"	G3/8"	200		M12x1	45	121100
168105		28	60	60	G1/4"	G3/8"	200		M12x1	45	121100
176105	G 63.01	36	50	63	G1/4"	G3/8"	208	170	M16x1,5	60	141100
177105	G 63.02	36	50,8	63	G1/4"	G3/8"	208	170	M16x1,5	60	141100
178105	G 63.03	36	60	63	G1/4"	G3/8"	208	170	M16x1,5	60	141100
180105	G 60.04	36	57,15	63	G1/4"	G3/8"	208	170	M16x1,5	60	141100

Grundkörper für ZPS SAY 20-6
Basic element for ZPS SAY 20-6

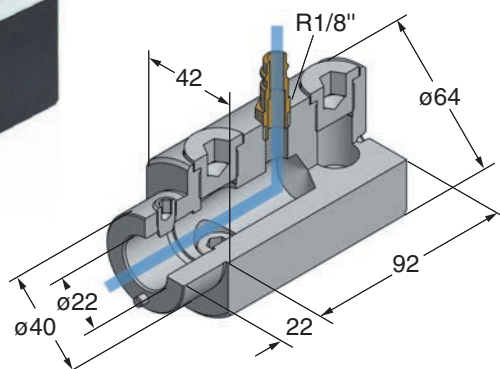
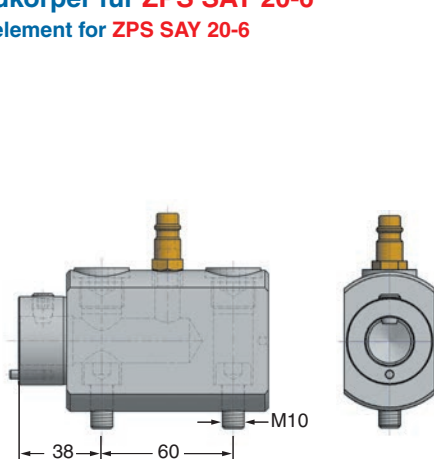

Art.-Nr.	Typ
250105	Grundkörper / Basic element

Grundkörper für ZPS SAY 25-6 + SAY 32-6
Basic element for ZPS SAY 25-6 + SAY 32-6



Radial justierbar + 6x60° umsetzbar
Radial adjustable + 6x60° changeable

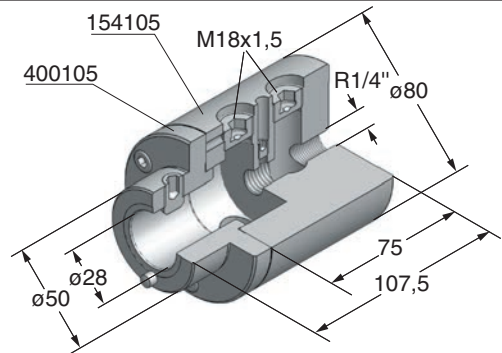
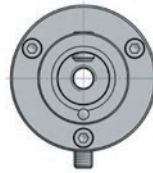
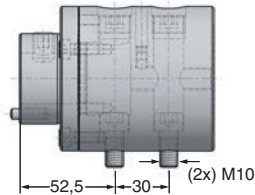

Spannzange / Collet ER40 / 472 E

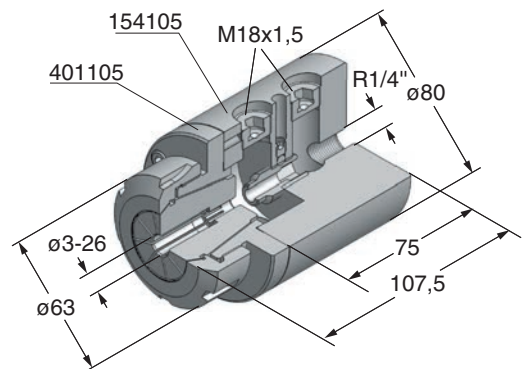
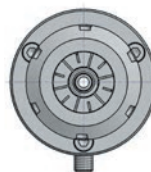
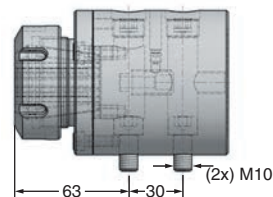

Art.-Nr.	Typ
154105	Grundkörper / Basic element
400105	Wechseleinsatz mini - fix Größe 6 / Quick-change insert size 6
401105	Wechseleinsatz Spannzangenfutter ER40 / Quick-change insert collet chuck ER40

Schnellbohrspindel für ZPS SAY 25-6 + SAY 32-6 mit innerer Kühlmittelzufuhr
High-speed drilling spindle for ZPS SAY 25-6 + SAY 32-6 with internal coolant

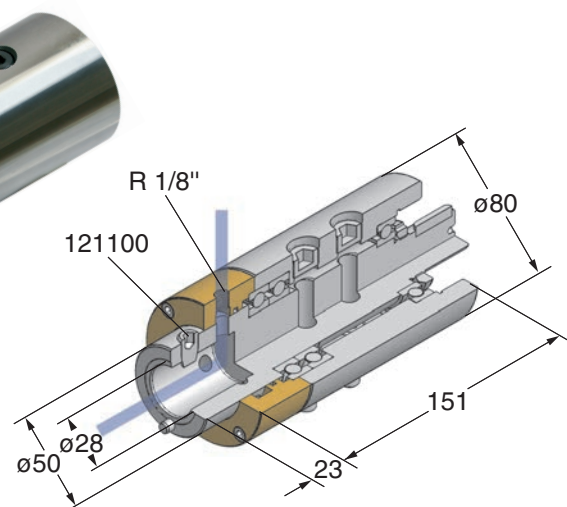
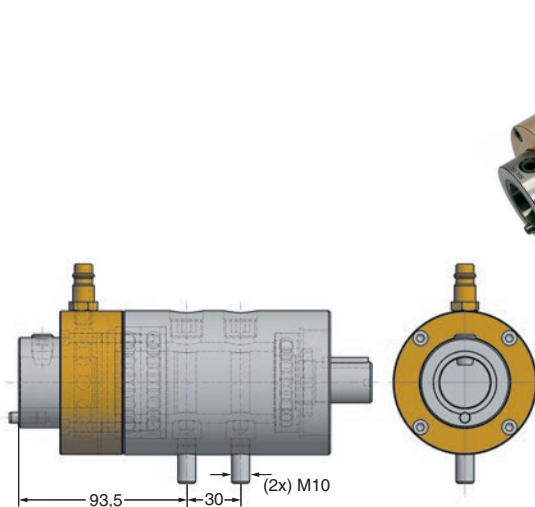

Art.-Nr.	Typ
183105	Schnellbohrspindel / High-speed drilling spindle

Grundkörper für INDEX MS25
Basic element for INDEX MS25



Radial justierbar + 6x60° umsetzbar
 Radial adjustable + 6x60° changeable

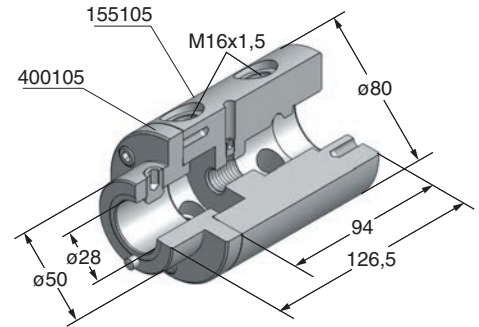
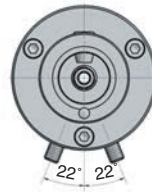
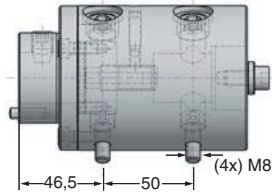

Spannzange / Collet ER40 / 472 E

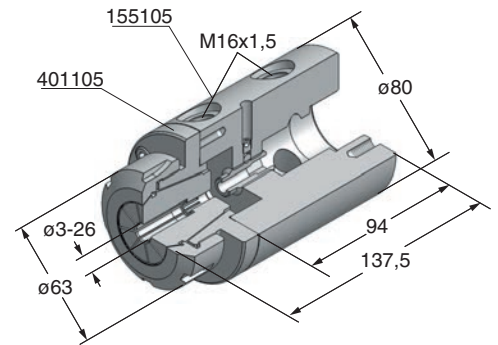
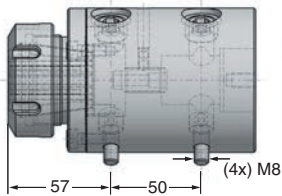

Art.-Nr.	Typ
155105	Grundkörper 7 Basic element
400105	Wechseleinsatz mini - fix Größe 6 / Quick-change insert size 6
401105	Wechseleinsatz Zangenfutter ER40 / Quick-change insert collet chuck ER40

Schnellbohrspindel für INDEX MS25 mit innerer Kühlmittelzufuhr
High-speed drilling spindle for INDEX MS25 with internal coolant

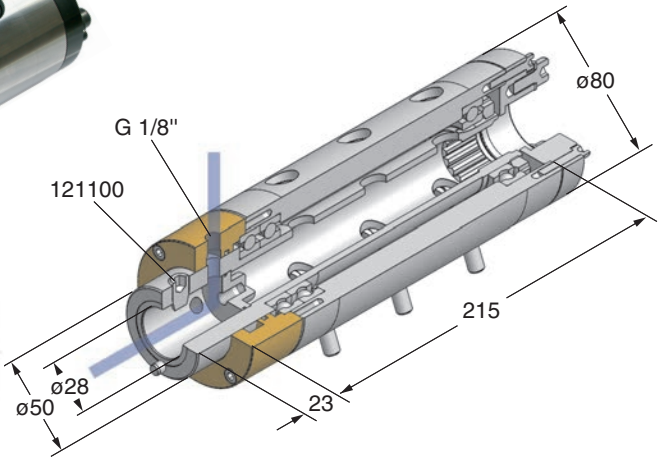
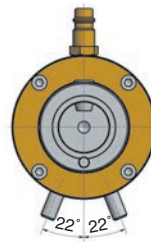
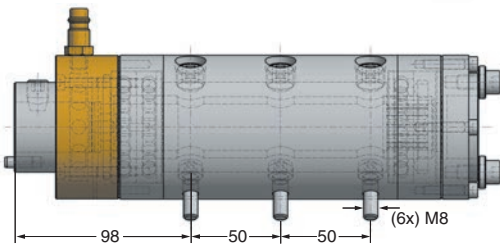

Art.-Nr.	Typ
175105	Schnellbohrspindel / High-speed drilling spindle

Grundkörper für Schütte mini-fix Größe 6
Basic element for Schütte mini-fix size 6

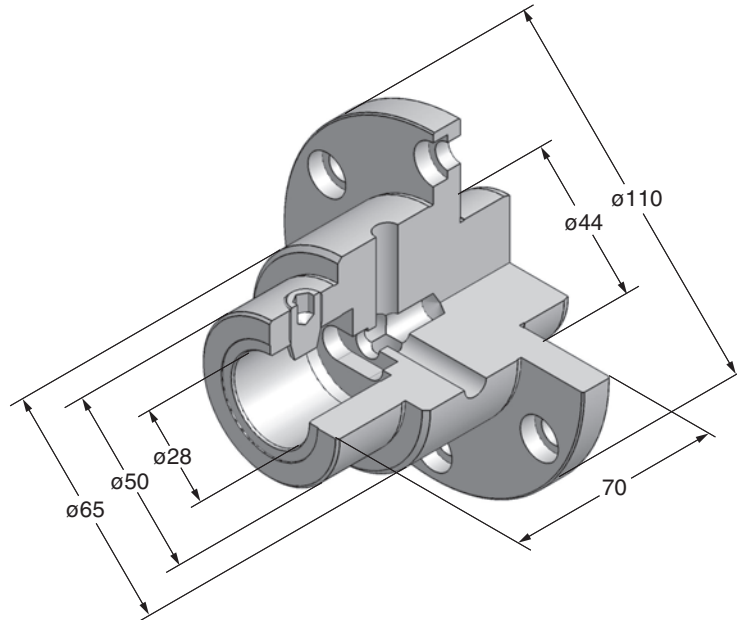

Art.-Nr.	Typ
208105	Grundkörper für Schütte mini-fix Größe 6 / Basic element for Schütte mini-fix size 6

Grundkörper für Schütte mini-fix Größe 7
Basic element for Schütte mini-fix size 7

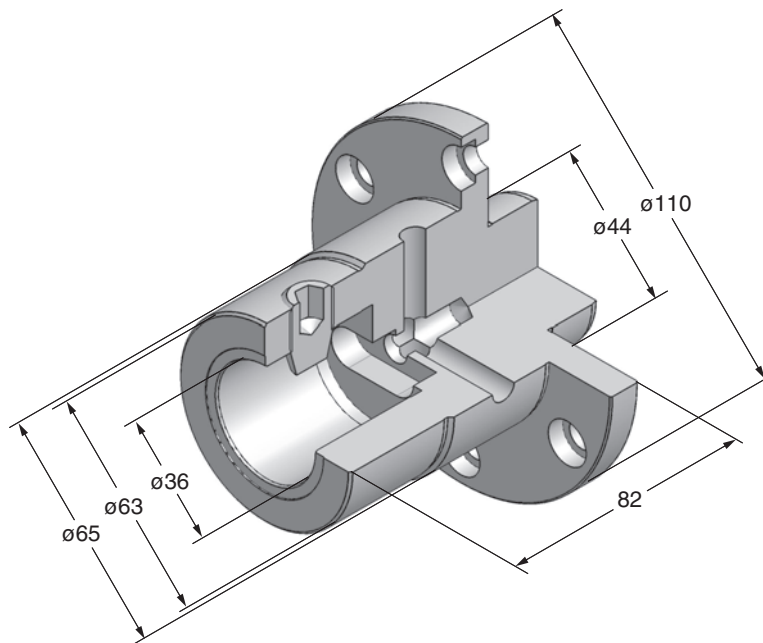

Art.-Nr.	Typ
209105	Grundkörper für Schütte mini-fix Größe 7 / Basic element for Schütte mini-fix size 7

Wechseleinsatz Spannzangenfutter für Spannzangen ER/ESX DIN 6499 / ISO 15488

Quick-change insert collet chuck for collets ER/ESX DIN 6499 / ISO 15488

Lieferumfang ohne Werkzeug und Spannzange
 Delivery without tool and collet

Alternative Spannmuttern siehe Seiten 15+16
 Alternative nuts see pages 15+16

Spannzangen siehe Seiten 18+19
 Collets see pages 18+19

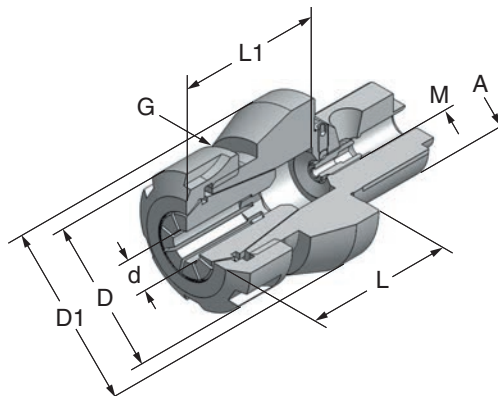

Art.-Nr.	Typ	A	D	D1	L	L1	M	d	Spannzange / Collet	G
261105	WE 23.01	13	22	23	35	32	M 4	1 - 10	ER 16 / 426 E	M22x1,5
270105	WE 28.01	16	22	28	40	35	M 5	1 - 10	ER 16 / 426 E	M22x1,5
281105	WE 32.00	18	22	32	37	32	M 5	1 - 10	ER 16 / 426 E	M22x1,5
282105	WE 32.01	18	34	32	40	37	M 5	1 - 13	ER 20 / 428 E	M25x1,5
293105	WE 35.01	20	28	35	40	35	M 5	1 - 10	ER 16 / 426 E	M22x1,5
294105	WE 35.02	20	34	35	40	35	M 5	1 - 13	ER 20 / 428 E	M25x1,5
296105	WE 39.01	22	28	39	50	45	M 8x1	1 - 10	ER 16 / 426 E	M22x1,5
297105	WE 39.02	22	34	39	50	45	M 8x1	1 - 13	ER 20 / 428 E	M25x1,5
298105	WE 39.03	22	42	39	50	45	M 8x1	1 - 16	ER 25 / 430 E	M32x1,5
311105	WE 50.00	28	22	50	70	65	M 8x1	1 - 10	ER 16 / 426 E	M22x1,5
312105	WE 50.01	28	42	50	50	40	M 8x1	1 - 16	ER 25 / 430 E	M32x1,5
313105	WE 50.02	28	50	50	50	40	M 8x1	2 - 20	ER 32 / 470 E	M40x1,5
314105	WE 50.03	28	63	50	60	50	M 8x1	3 - 30	ER 40 / 472 E	M50x1,5
327105	WE 63.01	36	42	63	60	50	M 8x1	1 - 16	ER 25 / 430 E	M32x1,5
328105	WE 63.02	36	50	63	60	50	M 8x1	2 - 20	ER 32 / 470 E	M40x1,5
329105	WE 63.03	36	63	63	60	50	M 8x1	3 - 30	ER 40 / 472 E	M50x1,5

Wechseleinsatz Pendelhalter, achsparallel ausgleichend einstellbar
Quick-change insert floating holder, axially parallel to the axis with adjustable compensation

Incl. Einsatz + Spannmutter
 Incl. insert + clamping nut

Lieferumfang ohne Werkzeug und Spannzange
 Delivery without tool and collet

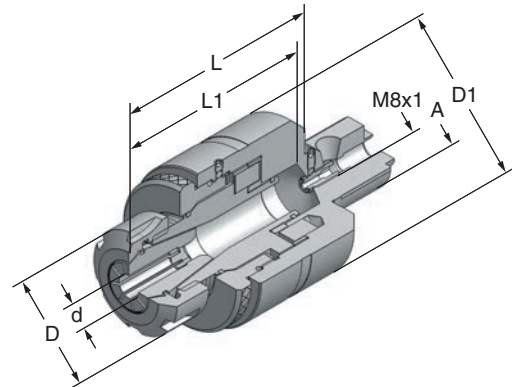

Art.-Nr.	Typ	A	D	D1	L	L1	d	Spannzange / Collet
392105	WE 39.14	22	22	44	65	45	1 - 10	ER 16 / 426 E
382105	WE 50.14	28	22	50	65	45	1 - 10	ER 16 / 426 E
383105	WE 50.15	28	42	63	88	50	1 - 16	ER 25 / 430 E
384105	WE 50.16	28	38	63	86	50	3 - 20	DA 180/419 E
390105	WE 63.15	36	42	63	88	50	1 - 16	ER 25 / 430 E
391105	WE 63.16	36	38	63	86	50	3 - 20	DA 180/419 E

Wechseleinsatz Gewindeschneidfutter
Quick-change insert auto taper

Lieferumfang ohne Werkzeug und Spannzange
 Delivery without tool and collet

Spannzangen siehe Seiten 18+19
 Collets see pages 18+19

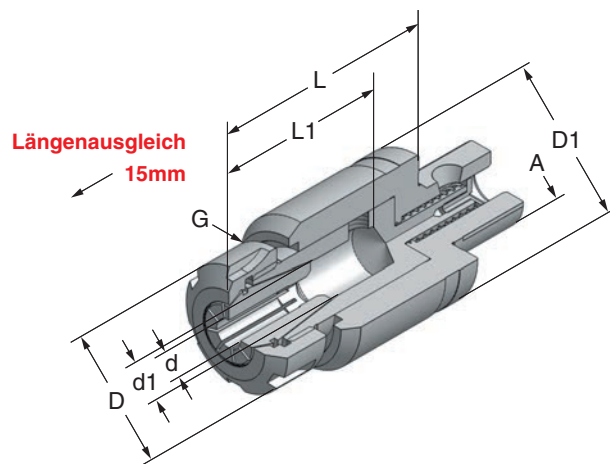

Art.-Nr.	Typ	A	D	D1	d1	L	L1	d	Spannzange / Collet	G
385105	WE 50.17	28	42	50	18	84	60	2-16 / M4-M20	ER 25 / 430 E	M32x1,5
385105-2	WE 50.17	28	50	50	21	101	50	3-20 / M4-M24	ER 32 / 470 E	M40x1,5
402105	WE 63.17	36	42	63	18	70	60	2-16 / M4-M20	ER 25 / 430 E	M32x1,5
402105-2	WE 63.17	36	50	63	21	87	50	3-20 / M4-M24	ER 32 / 470 E	M40x1,5

Wechseleinsatz Zylinderschaftaufnahme DIN 1835 B/E
Quick-change insert holder for straight shank tools DIN 1835 B/E

WE 39 / WE 50 = Weldon + Whistle Notch

WE 63 = Weldon

Lieferumfang ohne Werkzeug
 Delivery without tool

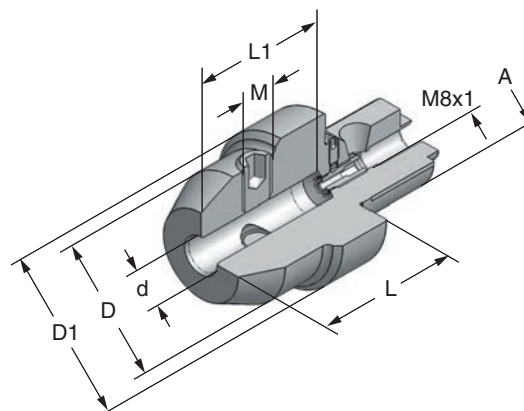

Art.-Nr.	Typ	A	d	D	D1	L	L1	M - Art.-Nr.
302105	WE 39.07	22	6	25	39	50	44	147100
303105	WE 39.08	22	8	28	39	50	44	148100
304105	WE 39.09	22	10	35	39	50	44	149100
305105	WE 39.10	22	12	39	39	50	47	150100
301105	WE 39.06	22	14	39	39	50	47	150100
306105	WE 39.11	22	16	39	39	60	50	151100
316105	WE 50.05	28	6	25	50	50	44	147100
317105	WE 50.06	28	8	28	50	50	44	148100
318105	WE 50.07	28	10	35	50	50	44	149100
319105	WE 50.08	28	12	42	50	50	47	150100
320105	WE 50.09	28	16	48	50	60	50	151100
310105	WE 50.21	28	18	48	50	60	50	151100
321105	WE 50.10	28	20	50	50	60	52	152100
325105	WE 50.22	28	25	50	50	65	58	127100
333105	WE 63.07	36	10	35	63	60	50	149100
334105	WE 63.08	36	12	42	63	60	50	150100
335105	WE 63.09	36	16	48	63	60	50	151100
336105	WE 63.10	36	20	50	63	60	52	152100
337105	WE 63.11	36	25	50	63	65	58	153100

Wechseleinsatz Ausdrehkopf System Zürn
Quick-change insert boring head System Zürn

Lieferumfang ohne Werkzeug
 Delivery without tool

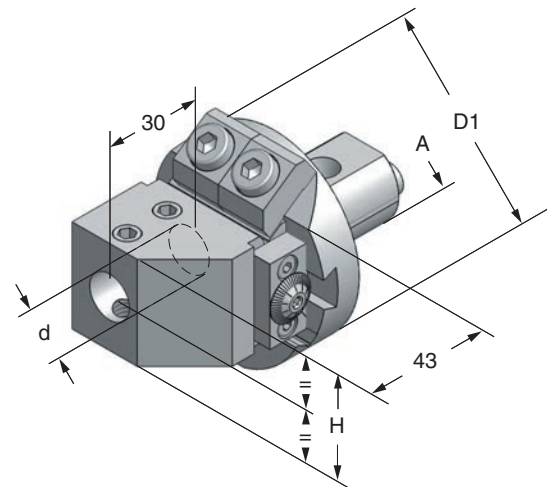

Art.-Nr.	Typ	A	D1	d	Dreh - max.	L	H
322105	WE 50.11	28	68			20	
339105	WE 63.11	36	83			24	
106121	WT 1070			8	25		37
107121	WT 1071			10	30		37
108121	WT 1072			12	40		37
109121	WT 1073			16	50		37
112121	WT 1076			18	50		42
110121	WT 1074			20	65		42
111121	WT 1075			25	75		46

Wechseleinsatz Spannzangenfutter Universal
Quick-change insert collet holder

Lieferumfang ohne Werkzeug
 Delivery without tool

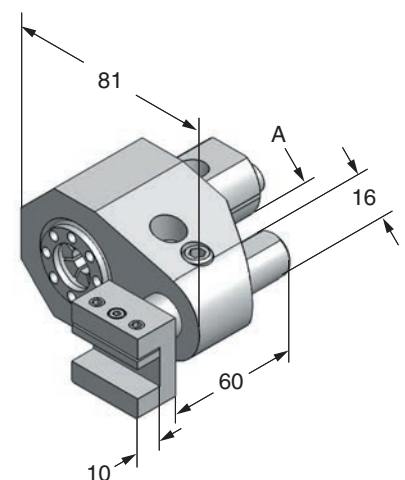
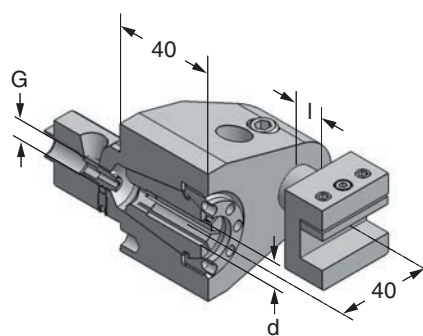

Art.-Nr.	A	I	d	Spannzange / Collet
347 105	28	0 - 35	1 - 16	ER 25 / 430 E

Wechseleinsatz Räumhalter für Innenprofile
Quick-change insert broaching toolholder for internal profiles

Lieferumfang ohne Räumstempel
Delivery without broaching cutter

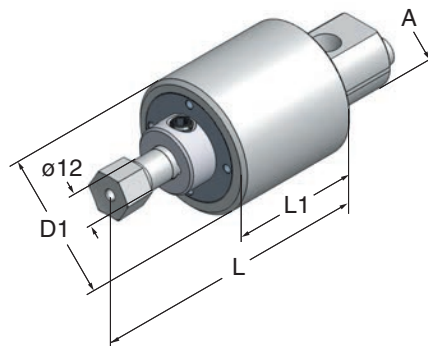

Art.-Nr.	A	D1	L	L1
397105	28	50	92	52
399105	36	63	92	52

Reduzierung
Reduction

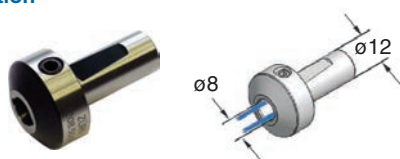





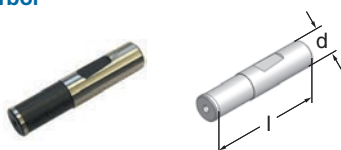



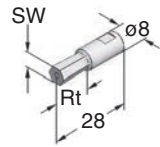

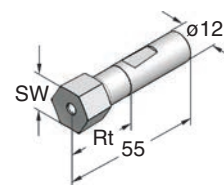
Art.-Nr.	Typ
1208.5000	Reduzierung / Reduction ø12/ø8

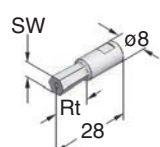
Kontrolldorn
Control arbor

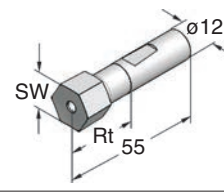

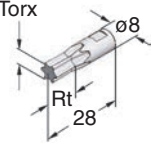
Art.-Nr.	d	l
08.5000	8	28
12.5000	12	55

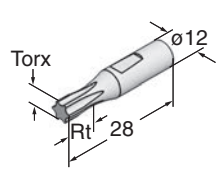
Räumstempel SW Hexagon-broaching cutters		Art.-Nr.	SW	ø	Rt = Räumtiefe		
TiN beschichtet TiN coated  		08.015	1,5	8	3		
		08.020	2	8	4		
 		08.025	2,5	8	4		
		08.030	3	8	5		
		08.040	4	8	7		
		08.050	5	8	9		
		08.060	6	8	11		
		08.070	7	8	11		
		08.080	8	8	11		
		08.100	10	8	14		
		12.040	4	12	7		
		12.050	5	12	9		
		12.060	6	12	11		
		12.070	7	12	13		
		12.080	8	12	15		
		12.090	9	12	16		
		12.100	10	12	19		
		12.110	11	12	19		
		12.120	12	12	19		
		12.130	13	12	19		
		12.140	14	12	24		
		12.150	15	12	24		
12.160	16	12	24				
12.170	17	12	24				
12.190	19	12	24				
12.220	22	12	24				
Räumstempel SW INCH Hexagon-broaching cutters INCH		Art.-Nr.	SW INCH	ø	Rt = Räumtiefe		
TiN beschichtet TiN coated  		08.3/32	3/32"	8	4		
		08.7/64	7/64"	8	4		
 		08.1/8	1/8"	8	5		
		08.3/16	3/16"	8	9		
		08.7/32	7/32"	8	9		
		08.1/4	1/4"	8	11		
		08.5/16	5/16"	8	11		
		08.3/8	3/8"	8	11		
		12.1/4	1/4"	12	11		
		12.3/8	3/8"	12	19		
		12.7/16	7/16"	12	19		
		12.1/2	1/2"	12	19		
		Räumstempel TORX EN ISO 10664 Broaching cutters TORX EN ISO 10664		Art.-Nr.	TORX	ø	Rt = Räumtiefe
		TiN beschichtet TiN coated  		08.T05	5	8	3
				08.T06	6	8	3
		 		08.T07	7	8	3
				08.T08	8	8	3
				08.T09	9	8	3
				08.T10	10	8	3
				08.T15	15	8	3
08.T20	20			8	4		
08.T25	25			8	4		
08.T27	27			8	4		
08.T30	30			8	4		
08.T40	40			8	5		
08.T45	45			8	5		
12.T50	50			12	7		
12.T55	55			12	10		

Wechseleinsatz Spannzangenfutter radial feinverstellbar
Quick-change insert collet chuck radially fine-adjustable

Lieferumfang ohne Werkzeug und Spannzange
 Delivery without tool and collet



Schnellwechselbar und voreinstellbar
Quick-change and pre-setting function

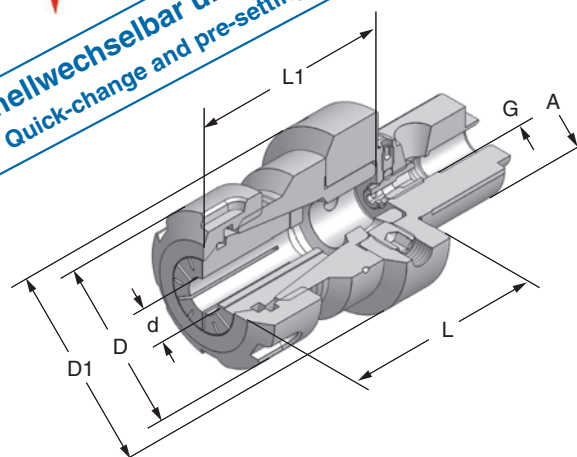
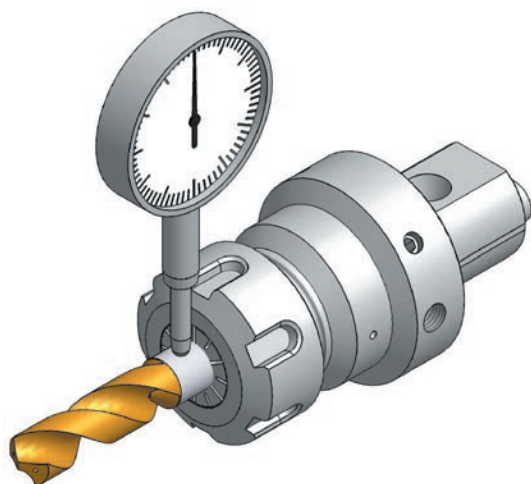

Art.-Nr.	Typ	A	D	D1	L	L1	G	d	Spannzange / Collet
440105	ER16	28	28	50	53,5	52,5	M8x1	ø1-10	ER 16 / 426 E
441105	ER25	28	42	50	60	59,5	M8x1	ø1-16	ER 25 / 430 E

Wechseleinsatz Rohling
Quick-change insert blank

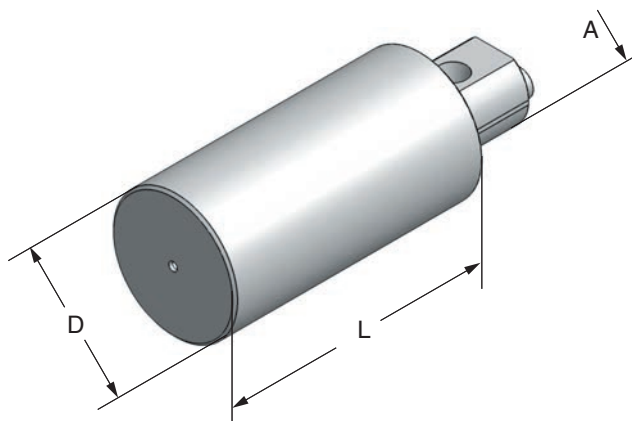

Art.-Nr.	Typ	A	D	L
308105	WE 39.12	22	39	75
323105	WE 50.12	28	50	100
338105	WE 63.12	36	63	125

Spannmuttern DIN 6499

Clamping nuts DIN 6499

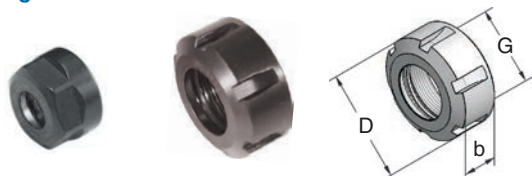

Art.-Nr. 711120 - SW17
Art.-Nr. 716120 - SW25
Spannschlüssel Typ EP

Art.-Nr. 720120 - 750120
Spannschlüssel Typ E

Spannmuttern DIN 6499 gleitgelagert

Clamping nuts DIN 6499 friction bearing

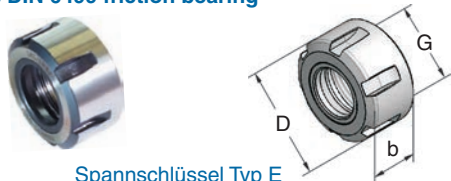

Spannschlüssel Typ E

Spannschlüssel

Key

Typ EP



Typ E



Art.-Nr.	Typ	D	b	G	Nm max.
711120	UMQ / ER11	19	11	M14x0,75	30
716120	UMQ / ER16	28	17	M22x1,50	70
720120	UMQ / ER20	34	19	M25x1,50	100
725120	UMQ / ER25	42	20	M32x1,50	130
732120	UMQ / ER32	50	22	M40x1,50	170
740120	UMQ / ER40	63	25	M50x1,50	220
750120	UMQ / ER50	78	35	M64x2,00	300

Art.-Nr.	Typ	D	b	G	Nm max.
716123	GMG / ER16	28	18	M22x1,50	70
720123	GMG / ER20	35	20	M25x1,50	100
725123	GMG / ER25	42	20	M32x1,50	130
732123	GMG / ER32	50	23	M40x1,50	170
740123	GMG / ER40	63	26	M50x1,50	220

Art.-Nr.	Typ	für Spannmutter	SW
911180	E 11 P	711120	17
916180	E 16 P	716120	25
920180	E 20 P		30
916181	E 16	716123, 716124, 716130	
920181	E 20	720120, 720123, 720124, 720130	
925180	E 25	725120, 725123, 725124, 725130	
932180	E 32	732120, 732123, 732124, 732130	
940180	E 40	740120, 740123, 740124, 740130	
950180	E 50	750120	

Spannmuttern DIN 6499 mini

Clamping nuts DIN 6499 mini

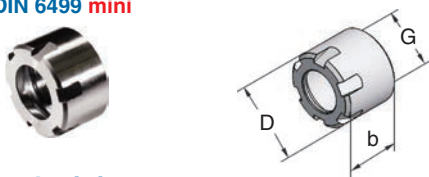

Spannschlüssel mini

Key mini



Art.-Nr.	Typ	D	b	G	Nm max.
908100	ER 8M	12	11	M10x0,75	6
911100	ER11M	16	11	M13x0,75	20
916100	ER16M	22	17	M19x1,00	30
920100	ER20M	28	19	M24x1,00	35
925100	ER25M	35	20	M30x1,00	40

Art.-Nr.	Typ	für Spannmutter
908160	E 8 mini	908100
911160	E 11 mini	911100
916160	E 16 mini	916100
920160	E 20 mini	920100
925160	E 25 mini	925100

Spannmuttern DIN 6499 mini

Clamping nuts DIN 6499 mini

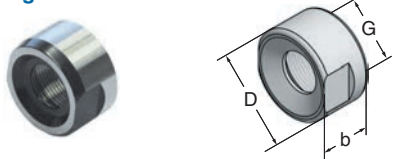
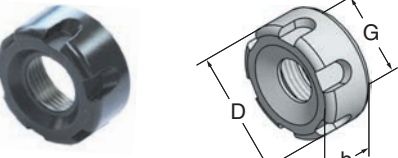
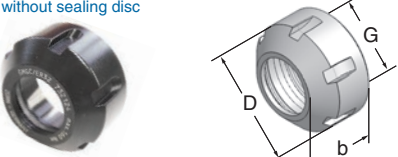
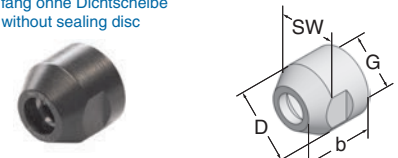
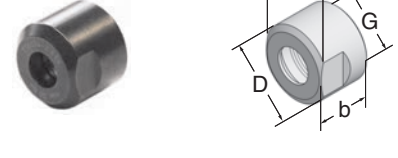
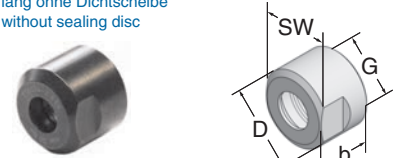
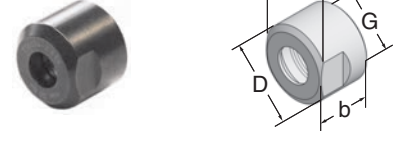

Art.-Nr.	Typ	D	b	G	SW	Nm max.
716120-2	ER16	25	17,5	M20x1,00	22	30
916162	Spannschlüssel ER16				22	

Spannmuttern ETS Clamping nuts ETS 	Art.-Nr. Typ D b G Spannschlüssel Nm max.
	709130 ETS 9 13,5 8 M10x0,75 762101 10 712130 ETS12 19 12 M14x0,75 912163 10 716120-2ETS ETS16 27 15 M20x1,00 916163 30
	Art.-Nr. Typ für Spannmutter
	762101 Spannschlüssel ETS 9 709130 912163 Spannschlüssel ETS12 712130 916163 Spannschlüssel ETS16 716120-2ETS
Spannmuttern DIN 6499 gleitgelagert für Dichtscheiben Clamping nuts DIN 6499 friction bearing for sealing discs <small>Lieferumfang ohne Dichtscheibe Delivery without sealing disc</small> 	Art.-Nr. Typ D b G Nm max. Dichtscheibe
	716124 GMGC / ER16 28 23 M22x1,5 70 excl. DS / ER16 720124 GMGC / ER20 34 25 M25x1,5 100 excl. DS / ER20 725124 GMGC / ER25 42 26 M32x1,5 130 excl. DS / ER25 732124 GMGC / ER32 50 28 M40x1,5 170 excl. DS / ER32 740124 GMGC / ER40 63 31 M50x1,5 220 excl. DS / ER40
Spannmuttern DIN 6499 mini für Dichtscheiben Clamping nuts DIN 6499 for sealing discs <small>Lieferumfang ohne Dichtscheibe Delivery without sealing disc</small> 	Art.-Nr. Typ D b G SW Nm max.
	716124-2 ER16C mini 25 22 M20x1,0 22 30 excl. Dichtscheibe/Sealing disc DS / ER16
	Art.-Nr. Typ D b G SW Nm max.
	916162 Spannschlüssel ER16 22
Spannmuttern ETS mini für Dichtscheiben Clamping nuts ETS mini for sealing discs <small>Lieferumfang ohne Dichtscheibe Delivery without sealing disc</small> 	Art.-Nr. Typ D b G SW Nm max.
	716124-2ETS ETS16C 27 22,5 M20x1,00 24 30 excl. Dichtscheibe/Sealing disc DS / ER16
	Art.-Nr. Typ SW Nm max.
	916163 Spannschlüssel ETS16 24

**Dichtscheiben für Spannmuttern DIN 6499, DIN 6388 & ETS
für Werkzeuge mit interner Kühlmittelzufuhr**

Sealing discs for clamping nuts DIN 6499, DIN 6388 & ETS
for tools with internal coolant supply

Kühlmitteldruck / Coolant pressure min. 5 bar - max. 100 bar

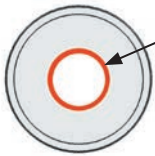

Der eingelegte O-Ring gewährleistet interne Kühlmittelzufuhr durch das gespannte Werkzeug direkt zur Werkzeugschneide

The inserted O-ring seal ensures a coolant supply internally through the clamped tool directly to the cutting edge

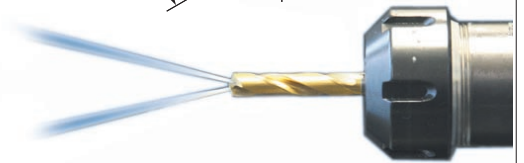
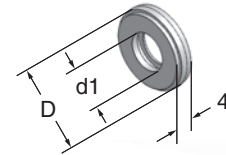
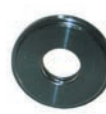

Art.-Nr.	Typ	D	d1	Art.-Nr.	Typ	D	d1
316040	DS/ER16	13	ø4 - 3	332040	DS/ER32	27	ø4 - 3
316050	DS/ER16	13	ø5 - 4	332050	DS/ER32	27	ø5 - 4
316060	DS/ER16	13	ø6 - 5	332060	DS/ER32	27	ø6 - 5
316070	DS/ER16	13	ø7 - 6	332070	DS/ER32	27	ø7 - 6
316080	DS/ER16	13	ø8 - 7	332080	DS/ER32	27	ø8 - 7
316090	DS/ER16	13	ø9 - 8	332090	DS/ER32	27	ø9 - 8
316100	DS/ER16	13	ø10 - 9	332100	DS/ER32	27	ø10 - 9
				332110	DS/ER32	27	ø11-10
320040	DS/ER20	16	ø4 - 3	332120	DS/ER32	27	ø12-11
320050	DS/ER20	16	ø5 - 4	332130	DS/ER32	27	ø13-12
320060	DS/ER20	16	ø6 - 5	332140	DS/ER32	27	ø14-13
320070	DS/ER20	16	ø7 - 6	332150	DS/ER32	27	ø15-14
320080	DS/ER20	16	ø8 - 7	332160	DS/ER32	27	ø16-15
320090	DS/ER20	16	ø9 - 8	332170	DS/ER32	27	ø17-16
320100	DS/ER20	16	ø10 - 9	332180	DS/ER32	27	ø18-17
320110	DS/ER20	16	ø11-10	332190	DS/ER32	27	ø19-18
320120	DS/ER20	16	ø12-11	332200	DS/ER32	27	ø20-19
320130	DS/ER20	16	ø13-12				
				340050	DS/ER40	33,5	ø5 - 4
325040	DS/ER25	21	ø4 - 3	340060	DS/ER40	33,5	ø6 - 5
325050	DS/ER25	21	ø5 - 4	340070	DS/ER40	33,5	ø7 - 6
325060	DS/ER25	21	ø6 - 5	340080	DS/ER40	33,5	ø8 - 7
325070	DS/ER25	21	ø7 - 6	340090	DS/ER40	33,5	ø9 - 8
325080	DS/ER25	21	ø8 - 7	340100	DS/ER40	33,5	ø10 - 9
325090	DS/ER25	21	ø9 - 8	340110	DS/ER40	33,5	ø11-10
325100	DS/ER25	21	ø10 - 9	340120	DS/ER40	33,5	ø12-11
325110	DS/ER25	21	ø11-10	340130	DS/ER40	33,5	ø13-12
325120	DS/ER25	21	ø12-11	340140	DS/ER40	33,5	ø14-13
325130	DS/ER25	21	ø13-12	340150	DS/ER40	33,5	ø15-14
325140	DS/ER25	21	ø14-13	340160	DS/ER40	33,5	ø16-15
325150	DS/ER25	21	ø15-14	340170	DS/ER40	33,5	ø17-16
325160	DS/ER25	21	ø16-15	340180	DS/ER40	33,5	ø18-17
				340190	DS/ER40	33,5	ø19-18
				340200	DS/ER40	33,5	ø20-19
				340210	DS/ER40	33,5	ø21-20
				340220	DS/ER40	33,5	ø22-21
				340230	DS/ER40	33,5	ø23-22
				340240	DS/ER40	33,5	ø24-23
				340250	DS/ER40	33,5	ø25-24
				340260	DS/ER40	33,5	ø26-25

**Dichtscheiben für Spannmuttern
Ortlieb DIN 6388
für Werkzeuge mit interner
Kühlmittelzufuhr**

Sealing discs for clamping nuts
Ortlieb DIN 6388
for tools with internal coolant supply

Art.-Nr.	Typ	D	d1
350050	DS/OZ25	31	ø5 - 4
350060	DS/OZ25	31	ø6 - 5
350070	DS/OZ25	31	ø7 - 6
350080	DS/OZ25	31	ø8 - 7
350090	DS/OZ25	31	ø9 - 8
350100	DS/OZ25	31	ø10 - 9
350110	DS/OZ25	31	ø11-10
350120	DS/OZ25	31	ø12-11
350130	DS/OZ25	31	ø13-12
350140	DS/OZ25	31	ø14-13
350150	DS/OZ25	31	ø15-14
350160	DS/OZ25	31	ø16-15
350170	DS/OZ25	31	ø17-16
350180	DS/OZ25	31	ø18-17
350190	DS/OZ25	31	ø19-18
350200	DS/OZ25	31	ø20-19
350210	DS/OZ25	31	ø21-20
350220	DS/OZ25	31	ø22-21
350230	DS/OZ25	31	ø23-22
350240	DS/OZ25	31	ø24-23
350250	DS/OZ25	31	ø25-24

Spannzangen ER/ESX DIN 6499-B rego-fix

Collets type ER/ESX DIN 6499-B rego-fix

Sätze / Sets 111002, 116002, 120002, 125002, 132002, 140002
nicht Original rego-fix / not original rego-fix



ER 8		ER 11/424 E		ER 16/426 E		ER 20/428 E	
Art.-Nr.	Spannbereich	Art.-Nr.	Spannbereich	Art.-Nr.	Spannbereich	Art.-Nr.	Spannbereich
108001	Satz / Set	111001	Satz / Set	116001	Satz / Set	120001	Satz / Set
		111002	Satz / Set	116002	Satz / Set	120002	Satz / Set
9 Stück/pcs. ø1-ø5		13 Stück/pcs. ø1-ø7		10 Stück/pcs. ø1-ø10		12 Stück/pcs. ø2-ø13	
108010	ø1,0 - 0,5	111010	ø1,0 - 0,5	116010	ø1,0 - 0,5	120010	ø1,0 - 0,5
108015	ø1,5 - 1,0	111015	ø1,5 - 1,0	116020	ø2,0 - 1,0	120020	ø2,0 - 1,0
108020	ø2,0 - 1,5	111020	ø2,0 - 1,5	116030	ø3,0 - 2,0	120030	ø3,0 - 2,0
108025	ø2,5 - 2,0	111025	ø2,5 - 2,0	116040	ø4,0 - 3,0	120040	ø4,0 - 3,0
108030	ø3,0 - 2,5	111030	ø3,0 - 2,5	116050	ø5,0 - 4,0	120050	ø5,0 - 4,0
108035	ø3,5 - 3,0	111035	ø3,5 - 3,0	116060	ø6,0 - 5,0	120060	ø6,0 - 5,0
108040	ø4,0 - 3,5	111040	ø4,0 - 3,5	116070	ø7,0 - 6,0	120070	ø7,0 - 6,0
108045	ø4,5 - 4,0	111045	ø4,5 - 4,0	116080	ø8,0 - 7,0	120080	ø8,0 - 7,0
108050	ø5,0 - 4,5	111050	ø5,0 - 4,5	116090	ø9,0 - 8,0	120090	ø9,0 - 8,0
		111055	ø5,5 - 5,0	116100	ø10,0 - 9,0	120100	ø10,0 - 9,0
		111060	ø6,0 - 5,5	ER 40/472 E		120110	ø11,0 - 10,0
		111065	ø6,5 - 6,0	140001	Satz / Set	120120	ø12,0 - 11,0
		111070	ø7,0 - 6,5	140002	Satz / Set	120130	ø13,0 - 12,0
ER 25/430 E		ER 32/470 E		23 Stück/pcs. ø3-ø26		ER 50/474 E	
125001	Satz / Set	132001	Satz / Set	140030	ø3,0 - 2,0	150001	Satz / Set
125002	Satz / Set	132002	Satz / Set	140040	ø4,0 - 3,0	12 Stück/pcs. ø10-ø34	
15 Stück/pcs. ø2-ø16		18 Stück/pcs. ø2-ø20		140050	ø6,0 - 5,0	150060	ø6,0 - 5,0
125010	ø1,0 - 0,5			140060	ø6,0 - 5,0	150080	ø8,0 - 6,0
125020	ø2,0 - 1,0	132020	ø2,0 - 1,0	140070	ø7,0 - 6,0	150100S	ø10,0 - 8,0
125030	ø3,0 - 2,0	132030	ø3,0 - 2,0	140080	ø8,0 - 7,0	150120	ø12,0 - 10,0
125040	ø4,0 - 3,0	132040	ø4,0 - 3,0	140090	ø9,0 - 8,0	150140	ø14,0 - 12,0
125050	ø5,0 - 4,0	132050	ø5,0 - 4,0	140100	ø10,0 - 9,0	150160	ø16,0 - 14,0
125060	ø6,0 - 5,0	132060	ø6,0 - 5,0	140110	ø11,0 - 10,0	150180	ø18,0 - 16,0
125070	ø7,0 - 6,0	132070	ø7,0 - 6,0	140120	ø12,0 - 11,0	150200	ø20,0 - 18,0
125080	ø8,0 - 7,0	132080	ø8,0 - 7,0	140130	ø13,0 - 12,0	150220	ø22,0 - 20,0
125090	ø9,0 - 8,0	132090	ø9,0 - 8,0	140140	ø14,0 - 13,0	150240	ø24,0 - 22,0
125100	ø10,0 - 9,0	132100	ø10,0 - 9,0	140150	ø15,0 - 14,0	150250	ø25,0 - 23,0
125110	ø11,0 - 10,0	132110	ø11,0 - 10,0	140160	ø16,0 - 15,0	150260	ø26,0 - 24,0
125120	ø12,0 - 11,0	132120	ø12,0 - 11,0	140170	ø17,0 - 16,0	150280	ø28,0 - 26,0
125130	ø13,0 - 12,0	132130	ø13,0 - 12,0	140180	ø18,0 - 17,0	150300	ø30,0 - 28,0
125140	ø14,0 - 13,0	132140	ø14,0 - 13,0	140190	ø19,0 - 18,0	150320	ø32,0 - 30,0
125150	ø15,0 - 14,0	132150	ø15,0 - 14,0	140200	ø20,0 - 19,0	150340	ø34,0 - 32,0
125160	ø16,0 - 15,0	132160	ø16,0 - 15,0	140210	ø21,0 - 20,0		
		132170	ø17,0 - 16,0	140220	ø22,0 - 21,0		
		132180	ø18,0 - 17,0	140230	ø23,0 - 22,0		
		132190	ø19,0 - 18,0	140240	ø24,0 - 23,0		
		132200	ø20,0 - 19,0	140250	ø25,0 - 24,0		
				140260	ø26,0 - 25,0		
				140270	ø27,0 - 26,0		
				140280	ø28,0 - 27,0		
				140290	ø29,0 - 28,0		
				140300	ø30,0 - 29,0		

Spannzangen DIN 6499 abgedichtet
für Werkzeuge mit Innenkühlung

Nur Nennmaßspannung

Collets DIN 6499 sealed
for tools with inner cooling systems

Only for nominal diameter



ER 16 C		ER 20 C		ER 25 C		ER 32 C	
Art.-Nr.	Spannbereich	Art.-Nr.	Spannbereich	Art.-Nr.	Spannbereich	Art.-Nr.	Spannbereich
116001C	Satz / Set	120001C	Satz / Set	125001C	Satz / Set	132001C	Satz / Set
8 Stück/pcs. ø3-ø10		10 Stück/pcs. ø4-ø13		13 Stück/pcs. ø4-ø16		17 Stück/pcs. ø4-ø20	
116030C	ø3,0	120030C	ø3,0	125030C	ø3,0	132030C	ø3,0
116040C	ø4,0	120040C	ø4,0	125040C	ø4,0	132040C	ø4,0
116050C	ø5,0	120050C	ø5,0	125050C	ø5,0	132050C	ø5,0
116060C	ø6,0	120060C	ø6,0	125060C	ø6,0	132060C	ø6,0
116070C	ø7,0	120070C	ø7,0	125070C	ø7,0	132070C	ø7,0
116080C	ø8,0	120080C	ø8,0	125080C	ø8,0	132080C	ø8,0
116090C	ø9,0	120090C	ø9,0	125090C	ø9,0	132090C	ø9,0
116100C	ø10,0	120100C	ø10,0	125100C	ø10,0	132100C	ø10,0
		120110C	ø11,0	125110C	ø11,0	132110C	ø11,0
		120120C	ø12,0	125120C	ø12,0	132120C	ø12,0
		120130C	ø13,0	125130C	ø13,0	132130C	ø13,0
ER 40 C		ER 50 C		125140C	ø14,0	132140C	ø14,0
140001C	Satz / Set	150001C	Satz / Set	125150C	ø15,0	132150C	ø15,0
23 Stück/pcs. ø4-ø26		7 Stück/pcs. ø8-ø32*		125160C	ø16,0	132160C	ø16,0
140040C	ø4,0	150120C	ø12,0			132170C	ø17,0
140050C	ø5,0	150130C	ø13,0			132180C	ø18,0
140060C	ø6,0	150140C	ø14,0			132190C	ø19,0
140070C	ø7,0	150150C	ø15,0			132200C	ø20,0
140080C	ø8,0	150160C	ø16,0				
140090C	ø9,0	150170C	ø17,0				
140100C	ø10,0	150180C	ø18,0				
140110C	ø11,0	150190C	ø19,0				
140120C	ø12,0	150200C	ø20,0				
140130C	ø13,0	150210C	ø21,0				
140140C	ø14,0	150220C	ø22,0				
140150C	ø15,0	150230C	ø23,0				
140160C	ø16,0	150240C	ø24,0				
140170C	ø17,0	150250C	ø25,0				
140180C	ø18,0	150260C	ø26,0				
140190C	ø19,0	150270C	ø27,0				
140200C	ø20,0	150280C	ø28,0				
140210C	ø21,0	150290C	ø29,0				
140220C	ø22,0	150300C	ø30,0				
140230C	ø23,0	150310C	ø31,0				
140240C	ø24,0	150320C	ø32,0				
140250C	ø25,0	150330C	ø33,0				
140260C	ø26,0	150340C	ø34,0				
		* ø8, 10, 12, 16, 20, 25, 32					



Schnellwechsel-System mini-fix

Quick-change system mini-fix

